

For more Project details visit:

<http://www.projectsof8051.com/rfid-based-security-system/>

Code	Project Title
1505	RFid Based Security System

Synopsis for

# RFID based Security System

## 1 Introduction

Most educational institutions' administrators are concerned about student security. The conventional method allowing access to students inside a college/educational campus is by showing photo i-cards to security guard is very time consuming and insecure, hence inefficient.

Radio Frequency Identification (RFID) based security system is one of the solutions to address this problem. This system can be used to allow access for student in school, college, and university. It also can be used to take attendance for workers in working places. Its ability to uniquely identify each person based on their RFID tag type of ID card make the process of allowing security access easier, faster and secure as compared to conventional method.

Students or workers only need to place their ID card on the reader and they will be allowed to enter the campus. And if any invalid card is shown then the buzzer is turned on.

## 2 Abstract

The security system is basically an embedded one. Embedded stands for hardware controlled by software. Here, the software using a Microcontroller controls all the hardware components. The microcontroller plays an important role in the system.

The main objective of the system is to uniquely identify and to make security for a person. This requires a unique product, which has the capability of distinguishing different person. This is possible by the new emerging technology RFID (Radio Frequency Identification). The main parts of an RFID system are RFID tag (with unique ID number) and RFID reader (for reading the RFID tag). In this system, RFID tag and RFID reader used are operating at 125 KHz. The microcontroller internal memory is used for storing the details.

This report provides a clear picture of hardware and software used in the system. It also provides an overall view with detailed discussion of the operation of the system.

## 3 Block Diagram

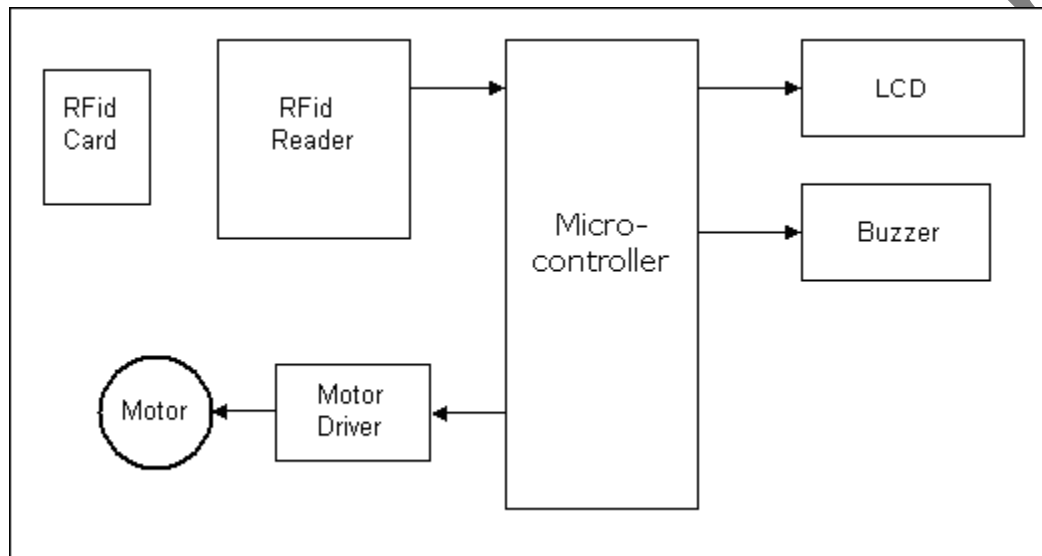

## 4 Block Diagram Description

### 1) Microcontroller

This is the most important segment of the project, i.e. the microcontroller 8051. The controller is responsible for detection and polling of the peripherals status. It is responsible for making decisions for the connected devices. It is responsible for prioritizing all the slaves attached to it.

We have used the ATMEL 89S51 microcontroller. The AT89S51 is a low-power, high-performance CMOS 8-bit microcontroller with 8K bytes of in-system programmable Flash

---

memory. It has got 32 I/O lines, Watchdog timer, two data pointers, three 16-bit timer/counters, six-vector two-level interrupt architecture, a full duplex serial port, on-chip oscillator, and a clock circuitry.

It is the major part of the system which controls all the operation of the circuit such as LCD interfacing, square wave generation. It also decides the messages to be displayed on the LCD along with the time duration for which they should be displayed on the LCD.

Microcontroller also decides the frequency of square wave output.

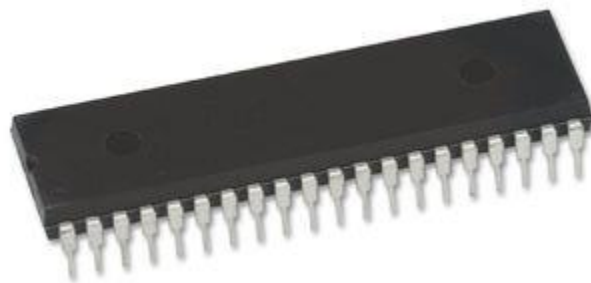

Figure: Photograph of an 89s51 microcontroller.

## 2) Liquid Crystal Display (LCD):

Liquid Crystal Display which is commonly known as Alphanumeric Display can display Alphabets, Numbers as well as special symbols thus alphabets. Graphic display has embedded controller for controlling different modes. Controller accepts commands and data bytes from micro controller.

LCD display has total 16 pins for interface with processor. RS is instruction or data select line. This pin is kept high or low by microcontroller to indicate command instruction or data

bytes on data bus db0-db7. Special feature of this LCD module is it allows reading of data bytes stored in RAM. Pin no. 5 i.e. R/W is used for deciding read operation or write operation. Graphic display has RAM memory for storing characters codes to be displayed on LCD.

We have used 16 x 2 Alphanumeric Display which means on this display we can display two lines with maximum of 16 characters in one line.

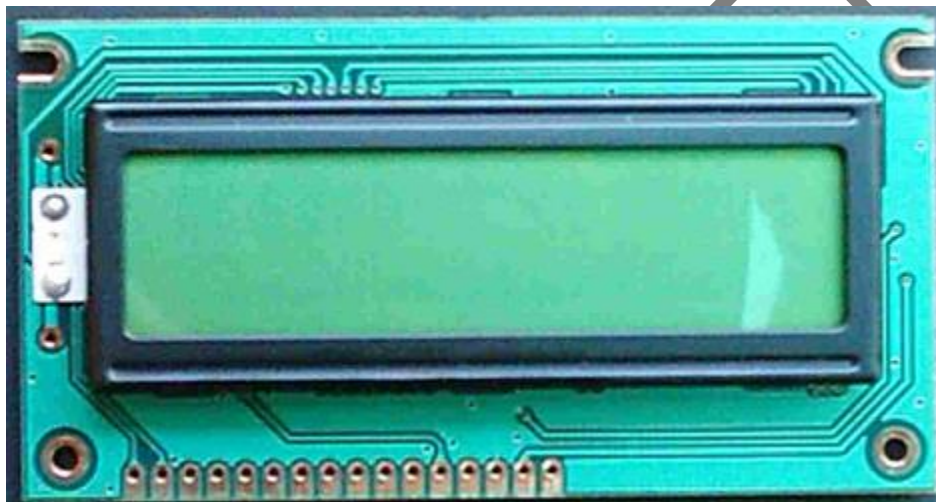

Figure: Photograph of A typical 16 by 2 alphanumeric LCD display

### 3) Motor

We have used a DC motor. It is used to open the gate.

### 4) RFID card reader

It reads the RFID card shown in front of it and then sends out the code of the respective card.

This code is sent through serial communication.

## Applications

### 1) In Educational institutes

It is used for the security in colleges, schools and universities.

### 2) In Companies / Industries

It is used for the security in software companies, industries.