

For more Project details visit:

<http://www.projectsof8051.com/gsm-based-lpg-weight-and-lpg-leakage-detection-system/>

Code	Project Title
1632	LPG weight and LPG Leakage Detection System using GSM

Synopsis for LPG weight and LPG Leakage Detection System using GSM

1.Introduction

Many times LPG gas cylinder in our home goes empty. And if the LPG gas provider agency does not deliver gas on time then we face many problems due to unavailability of LPG gas. Another major problem is that many times accidentally there is LPG gas leakage. Which can cause fire in house. To avoid above two problems, we are going to implement a project which performs respective two functions. First is to detect the weight of LPG gas cylinder. And the second one is to detect the LPG gas leakage.

Weight sensor is used to detect if the cylinder is empty or not. If the cylinder is empty then an alert is given with the help of buzzer. Also a sms is sent to the owner. This project measures and displays the value of LPG gas leakage. LCD display connected to this project displays this value of LPG gas. LPG gas sensor is used to detect the gas leakage. If there is leakage then buzzer is turned on. GSM modem is used to send the SMS whenever there is gas leakage.

2. Block Diagram

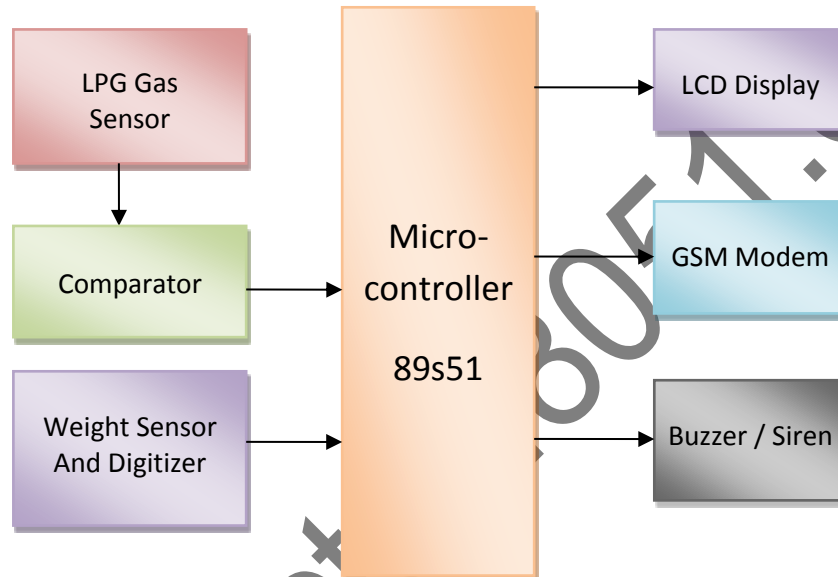

3. Block Diagram Description

It mainly consist of following blocks

1. Microcontroller: This is the CPU (central processing unit) of our project. We are going to use a microcontroller of 8051 family. The various functions of microcontroller are like

I. Reading the weight sensor and LPG sensor values

II. Sending this data to LCD so that the person operating this project should it.

III. Sending the data to the GSM modem using serial port.

2. LCD: We are going to use 16x2 alphanumeric Liquid Crystal Display (LCD) which means it can display alphabets along with numbers on 2 lines each containing 16 characters.

3. GSM Modem: We are going to use sim300 as a GSM modem. LPG Gas leakage status will be sent to GSM modem.

Application and Advantage:

1. Can be used in hotels, home.
2. This can also be used in Industries.

Future Development:

1. We can implement other related modules like fire sensor, wind sensor.
2. We can add the module of voice alarm system to the status.

For more Project details visit:

<http://www.projectsof8051.com/gsm-based-lpg-weight-and-lpg-leakage-detection-system/>