

For more Project details visit:

<http://www.projectsof8051.com/fingerprint-based-attendance-management-system/>

Code	Project Title
1902	Fingerprint based attendance management system

## Synopsis for Fingerprint based attendance management system

### Introduction

This project can be used at many places like Industries, Offices, and Colleges or even at various shops & malls. First we have to operate this project in “Settings mode or Admin mode”. In this mode we have to enter data into the database of finger print sensor, for this we have to take impressions of fingerprints of that person whom we want to give access to our security system. This can be done once or whenever a new entry has to be added in the system. Then use this project in “Normal mode or Search mode”. In this mode the system compares the fingerprint input received at its optical plate with the previously stored fingerprint from its flash memory. If the entry matches with the memory then it gives out ok signal along with the identity number of that person. But if the entry does not match with the memory then it gives out error signal. The output received from fingerprint sensor is given to the microcontroller. Microcontroller then compares these output data. Function of microcontroller is to store attendance depending upon the input received. In case of OK signal from fingerprint module, microcontroller stores attendance. However if the error output is received then it turns on the Buzzer

## Block Diagram

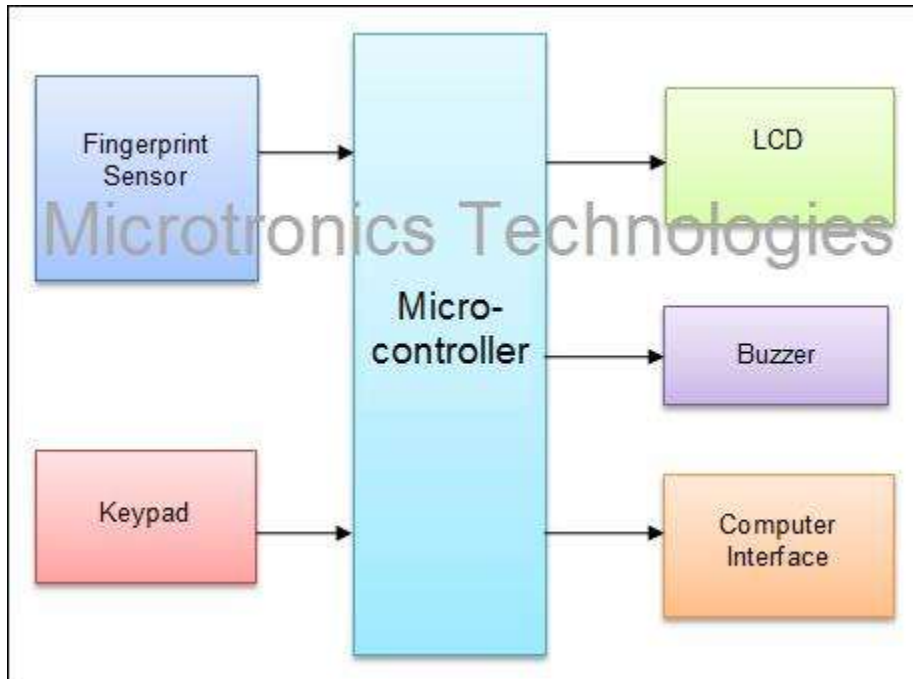

## Block Diagram Description

Following are the important blocks of this system:

- 1) Fingerprint sensor
- 2) Microcontroller
- 3) LCD Display
- 4) Buzzer
- 5) Keypad

## Applications

- This project can be used by the employees, staff or workers in various industries like Automobile industries, manufacturing industries, Software development companies.

For more Project details visit:

<http://www.projectsof8051.com/fingerprint-based-attendance-management-system/>

---